

RUBBER TOP CHAINS

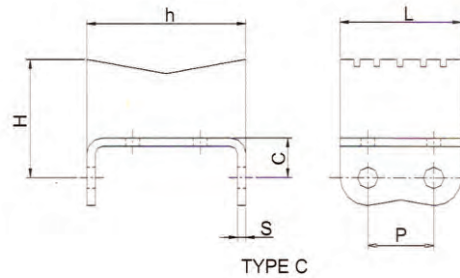
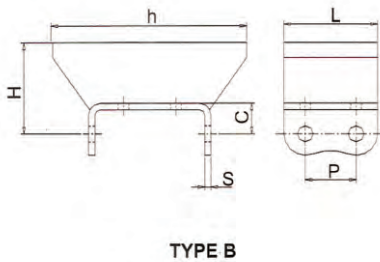
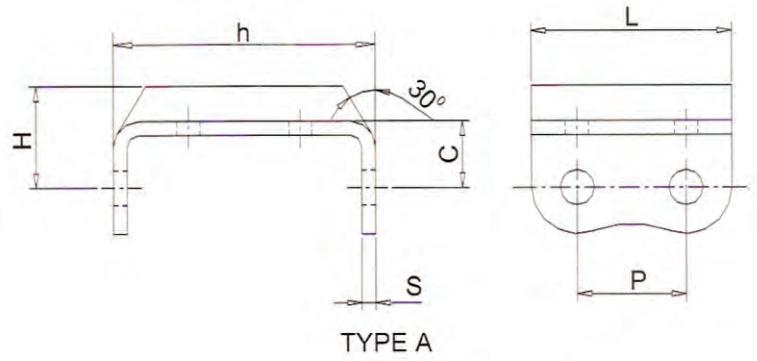
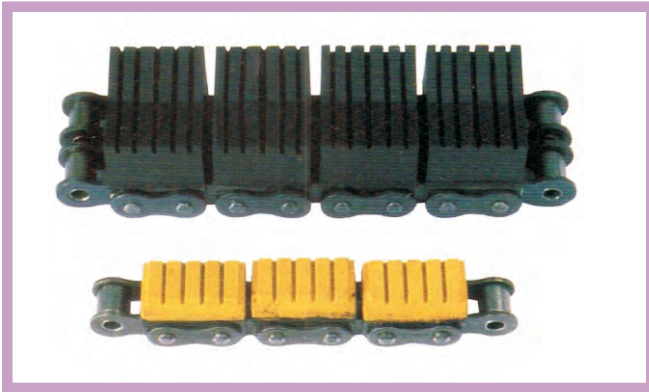

*These chains are designed to face special needs in wood, tile, glass, carton printing, PVC tube extrusion industries.

*The rubber attachment can be supplied with precision single or duplex roller chains.

*Special Profiles can be made on request

Grade	Natural Rubber	Nitrile Rubber	Neoprene Rubber
SHORE HARDNESS (A)	65 +/- 5	65 +/- 5	65 +/- 5
TEMPERATURE RANGE	-10 TO + 70 deg c.	-10 TO + 70 deg c.	-10 TO + 80 deg c.
RESISTANCE TO OIL/ GREASE	POOR	EXCELLENT	FAIR
OZONE / UV RESISTANCE	POOR	FAIR	EXCELLENT

Intl Ref No.	DIAMOND Chain No.	Type	Pitch (P)	Width over Bearing Pin (A)	C	H	h	L	S	Tensile Strength (Kgf) (Min)
08B - 1	D08301R T01	A	12.70	17.80	8.30	12.30	14.72	24.00	1.50	1840
80 - 1	D16101R T01	A	25.40	38.00	18.30	23.00	27.50	49.40	3.15	5780
08B - 2	D08302R T01	B	12.70	33.90	9.50	18.30	44.00	24.00	1.50	3270
08B - 2	D08302R T02	A	12.70	33.90	9.50	12.50	28.50	24.00	1.50	3270
60 - 2	D12102R T01	C	19.05	53.00	11.80	33.80	45.56	34.87	2.00	6490