



**DRIVES & DRIVES**®

Total Mechanical Power Transmission Solutions and Lifting Products.

# EASY LIFTING



Designed & Manufactured by Drives & Drives  
All Designs Certified by Licensed  
Civil and Structural Chartered Engineer



## Lifting Tackles and Spreader Beam

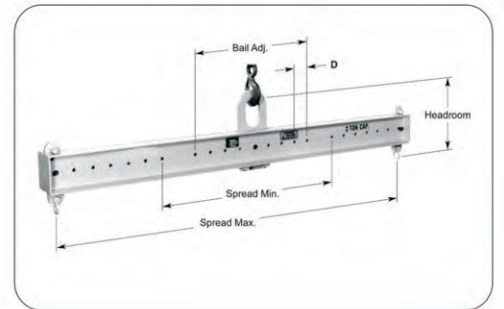
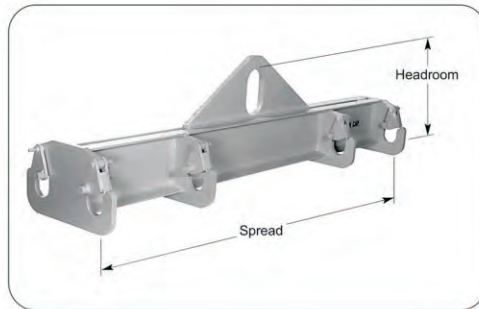
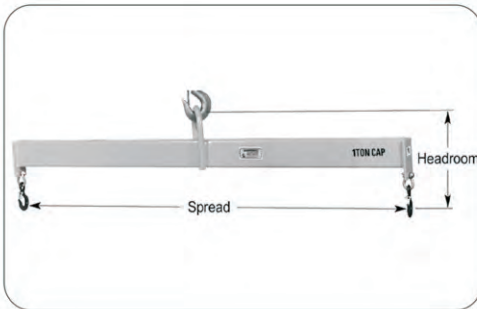
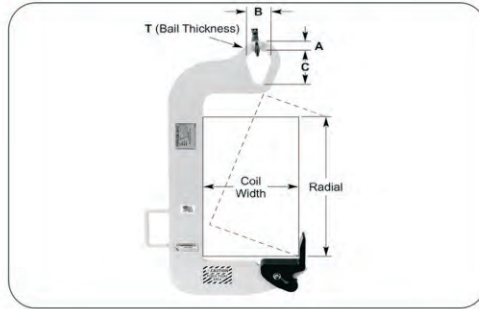
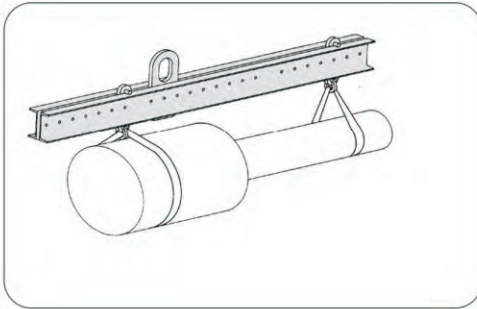
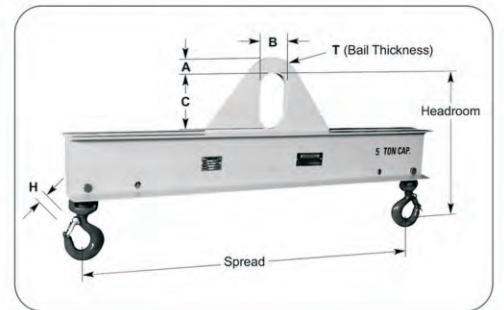
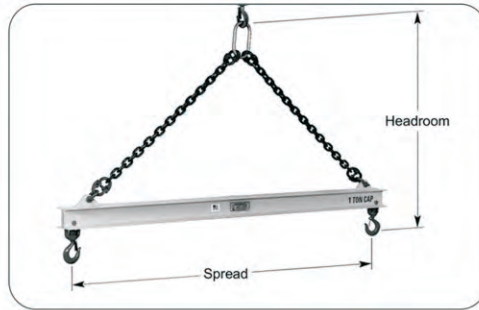
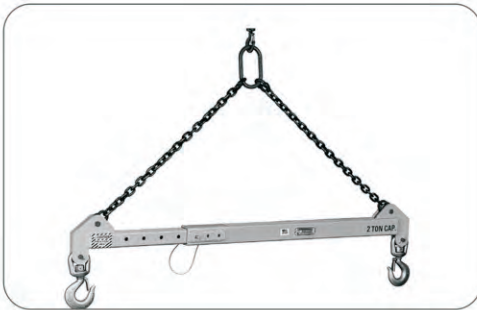



**DRIVES & DRIVES**®

Total Mechanical Power Transmission Solutions and Lifting Products.

# COIL LIFTERS

## Coil Hook with Pivoting Wedge (ÖÖCH)

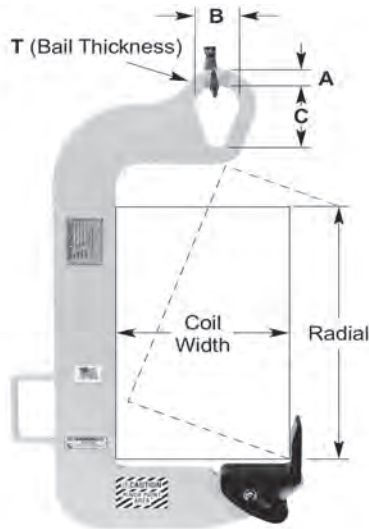

### FEATURES

- For easy upending of coils from horizontal to vertical
- Pivoting wedge great for lifting coils that have been stacked
- Wedge also acts as a coil retainer
- Excels in use with small, lightweight coils
- Good for limited overhead clearance
- Standard handle for easier coil positioning

RATED CAP. (Tons)	PART NO.	MAX COIL WIDTH(mm)	MAX RADIAL (mm)	MIN ID (mm)
0.5	DDCH 1X6	152	330	228
0.5	DDCH 1X12	304	330	330
1	DDCH 2X8	203	406	254
2	DDCH 4X10	254	458	316
3.5	DDCH 7X12	304	508	368

## Heavy Duty Coil Hook (DHÖÖ)

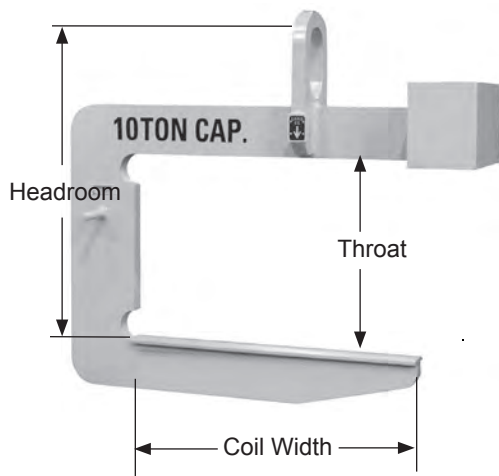

### FEATURES

- Designed for heavy duty applications
- High tensile alloy steel plate reduces physical size and weight
- Counter balanced to hang level when empty
- Inside radius on hooks avoid coil edge contact
- Guide handles for ease of hook positioning
- Handles a wide range of coil widths
- Available with optional padding for additional coil protection

RATED CAP. (Tons)	PART NO.	MAX/ MIN COIL WIDTH (mm)	THROAT (mm)
5	DHCL 10X36	914/610	610
5	DHCL 10X48	1218/762	610
5	DHCL 10X60	1524/914	610
7.5	DHCL 15X36	914/610	610
7.5	DHCL 15X48	1218/762	610
7.5	DHCL 15X60	1524/914	610
10	DHCL 20X48	1218/762	610
10	DHCL 20X60	1524/914	610
10	DHCL 20X72	1828/1066	610
15	DHCL 30X48	1218/762	762
15	DHCL 30X60	1524/914	762
15	DHCL 30X72	1828/1066	762
20	DHCL 40X60	1524/914	762
20	DHCL 40X72	1828/1066	762



**DRIVES & DRIVES**®

Total Mechanical Power Transmission Solutions and Lifting Products.

# LIFTING BEAMS

## Adjustable Spreader/Lifting Beam (ÖASB)

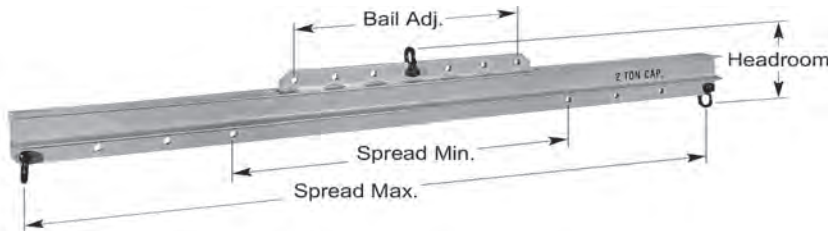

### FEATURES

- Use for 2, 3 or 4 point lifting or as spreader beam (add top rigging)
- Adjustable lifting points
- Good for unbalanced loads
- Low headroom
- Shackles included
- 6" spread adjustments
- 4" bail adjustments

### OPTIONS

- Pair of swivel hooks - Code S\*
- Top chain rigging - Code C

RATED CAP. (Tons)	MODEL NO.	SPREAD (FT)		BAIL ADJ. (mm)	HEADROOM (mm)
		MAX.	MIN.		
0.25	DASB.5	4	1	406	410
0.5	DASB1	6	3	610	410
1	DASB2	6	3	610	410
2	DASB4	6	3	610	410
4	DASB8	8	4	812	590
5	DASB10	10	5	1016	640
7	DASB14	12	6	1219	760

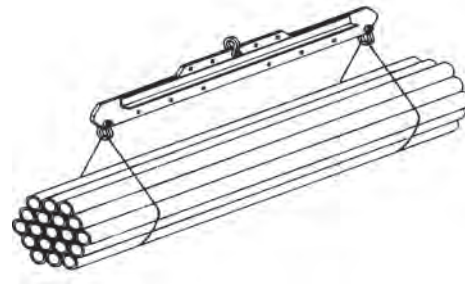

## Adjustable Lifting Beam (DALB)

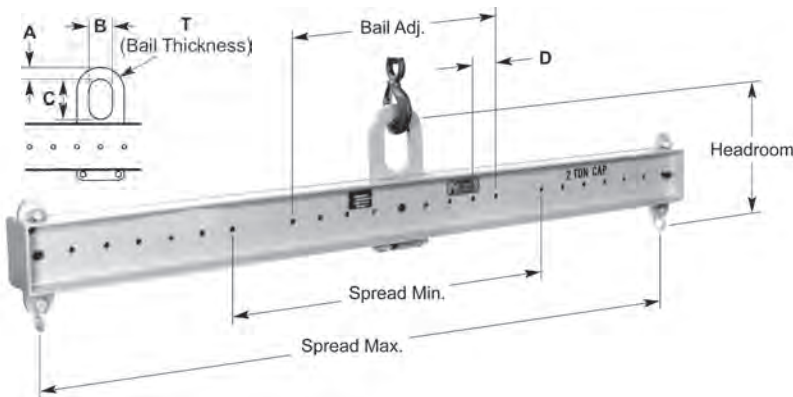

### FEATURES

- Adjust bail for unbalanced load
- 6" spread adjustments
- Shackles included

### OPTIONS

- Pair of swivel hooks - Code S\*

RATED CAP. (Tons)	MODEL NO.	SPREAD (FT)		BAIL ADJ. (mm)	HEADROOM (mm)
		MAX.	MIN.		
1.25	DALB2.5	6	3	610	400
2	DALB4	6	3	610	400
4	DALB8	8	4.5	914	500

Bail Adjustment for Unbalanced Loads

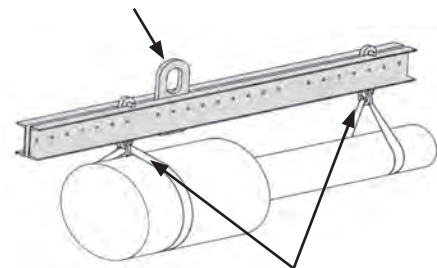

Lift Point Adjustment for Load Length



**DRIVES & DRIVES**<sup>®</sup>

Total Mechanical Power Transmission Solutions  
and Lifting Products.

## ..... LIFTING BEAMS

### Fixed Spread Lifting Beam (ÖFSL)

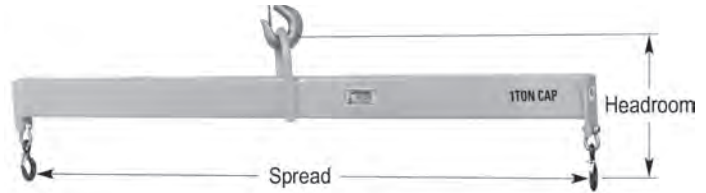

#### FEATURES

- Fixed spread lifting
- Eye hooks with latches
- Sealed construction for cleaner beam

RATED CAP. (Tons)	MODEL NO.	SPREAD (FT)	HEADROOM (mm)
0.5	DFSL 1X6	6	300
0.5	DFSL 1X8	8	300
0.5	DFSL 1X10	10	350
1	DFSL 2X6	6	350
1	DFSL 2X8	8	400
1	DFSL 2X10	10	400
2	DFSL 4X6	6	450
2	DFSL 4X8	8	500
2	DFSL 4X10	10	500
3	DFSL 6X6	6	580
3	DFSL 6X8	8	580
3	DFSL 6X10	10	580

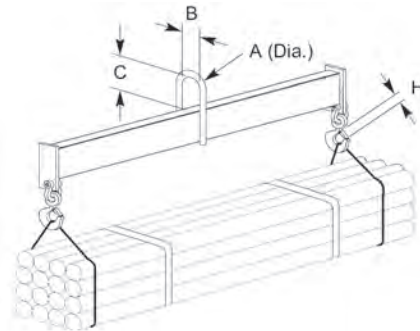

**DRIVES & DRIVES**<sup>®</sup>

Total Mechanical Power Transmission Solutions  
and Lifting Products.

Shop No.12, Arihant Building,  
Gopal Krishna Gokhale Road,  
Mulund (E), Mumbai 400081.

Tel: 022-21633694, 09322641435

Fax: 022-21632758.

Email: [ddlifting@gmail.com](mailto:ddlifting@gmail.com) Web: [www.drivesanddrives.com](http://www.drivesanddrives.com)